

Artículo de investigación

Evaluation of the regional environment promoting development of scientific activity

Evaluación del entorno regional que promueve el desarrollo de la actividad científica

Avaliação do ambiente regional promovendo o desenvolvimento da atividade científica

Recibido: 20 de abril de 2018. Aceptado: 10 de mayo de 2018

Written by:

Anna Maltseva³⁶

Elena Klyushnikova³⁷

Natalia Barsukova³⁸

Aleksandra Gridchina³⁹

Abstract

The paper is devoted to the research of regional environment's current state, that promoting development of scientific and technological activity in the Russian Federation's subjects.

For the study purposes we developed a system of primary indicators that characterizes the potential and the results of the functioning of the research and development sector in the regions. The information sources for forming the system of indicators are official statistics and systematized data from official sources that are freely available on the Internet.

The Index of the regional scientific environment was calculated and the rating of the Russian Federation's subjects was formed based on the method developed by the authors.

The index structure corresponds to five key tasks identified in the Strategy for Scientific and Technological Development of the Russian Federation.

Approbation of the developed methodology was carried out on the materials of 85 subjects of the Russian Federation.

Resumen

El documento está dedicado a la investigación del estado actual del entorno regional, que promueve el desarrollo de la actividad científica y tecnológica en los temas de la Federación de Rusia.

Para los fines del estudio, desarrollamos un sistema de indicadores primarios que caracteriza el potencial y los resultados del funcionamiento del sector de investigación y desarrollo en las regiones. Las fuentes de información para formar el sistema de indicadores son estadísticas oficiales y datos sistematizados de fuentes oficiales que están disponibles gratuitamente en Internet.

Se calculó el índice del entorno científico regional y se formó la calificación de las asignaturas de la Federación de Rusia en función del método desarrollado por los autores.

La estructura del índice corresponde a cinco tareas clave identificadas en la Estrategia para el

³⁶ Lurye Scientific and Methodological Center;for Higher School Innovative Activity of Tver State University, Russia; I70021, Russia, Tver, Proshina str., 5-1, 13.info@ores.su

³⁷ Lurye Scientific and Methodological Center;for Higher School Innovative Activity of Tver State University, Russia; I70021, Russia, Tver, Guseva boulevard, 47-1, 178

³⁸ Lurye Scientific and Methodological Center;for Higher School Innovative Activity of Tver State University, Russia; I70030, Russia, Tver, Koroleva str., 5, 96

³⁹ Department of public administration and law, Moscow Polytechnic University, Moscow, Russia I29301, Russia, Moscow, Boris Galushkin str., 15, 56

The study's obtained results are visualized using the map of intensity of the development of the regional scientific environment.

Recommendations for the development of the regional scientific environment and scientific and technological activities in the regions have been developed based on the results obtained in the study.

The study's results can be used for the purposes of regional management of the science sector's development.

Keywords: region, environment, science, technology, R&D, index.

Desarrollo Científico y Tecnológico de la Federación de Rusia.

La aprobación de la metodología desarrollada se llevó a cabo en los materiales de 85 sujetos de la Federación de Rusia.

Los resultados obtenidos del estudio se visualizan utilizando el mapa de intensidad del desarrollo del entorno científico regional.

Las recomendaciones para el desarrollo del entorno científico regional y las actividades científicas y tecnológicas en las regiones se han desarrollado sobre la base de los resultados obtenidos en el estudio.

Los resultados del estudio pueden utilizarse para los fines de la gestión regional del desarrollo del sector de la ciencia.

Palabras clave: región, medio ambiente, ciencia, tecnología, I + D, índice.

Resumo

O documento é dedicado à investigação do estado atual do ambiente regional, que promove o desenvolvimento da atividade científica e tecnológica nos assuntos da Federação Russa.

Para os propósitos do estudo, desenvolvemos um sistema de indicadores primários que caracteriza o potencial e os resultados da operação do setor de pesquisa e desenvolvimento nas regiões. As fontes de informação para formar o sistema de indicadores são estatísticas oficiais e sistematizadas de fontes oficiais disponíveis gratuitamente na Internet.

O índice do ambiente científico regional foi calculado e a qualificação dos sujeitos da Federação Russa foi formada de acordo com o método desenvolvido pelos autores.

A estrutura do índice corresponde a cinco tarefas-chave identificadas na Estratégia para o Desenvolvimento Científico e Tecnológico da Federação Russa.

A aprovação da metodologia desenvolvida foi realizada nos materiais de 85 sujeitos da Federação Russa. Os resultados obtidos no estudo são visualizados utilizando o mapa de intensidade do desenvolvimento do ambiente científico regional.

As recomendações para o desenvolvimento do ambiente científico regional e as atividades científicas e tecnológicas nas regiões foram desenvolvidas com base nos resultados obtidos no estudo.

Os resultados do estudo podem ser utilizados para os propósitos da gestão regional do desenvolvimento do setor de ciências.

Palavras-chave: região, meio ambiente, ciência, tecnologia, P & D, índice.

Introduction

The urgency of researching the issues of the current state of development of scientific activity in the regions is due to the special importance of the research and development sector for the outstripping growth of the economy of the Russian Federation's subjects, which is indicated in the Strategy for Scientific and Technological Development of the Russian Federation.

For example, the document specifies that it is necessary to consolidate the efforts of federal government bodies, state authorities of the Russian Federation's subjects, scientific and educational and business communities, civil society institutions to create favorable conditions for the application of scientific and technical achievements for Russia's social and economic development (Strategy of scientific and technological development of the Russian Federation).

Among the main directions and measures for the implementation of the state policy in the field of scientific and technological development of the Russian Federation there are the issues of the formation and development of infrastructure and environment, implying the creation of conditions for research and development that meet the modern principles of scientific, scientific and technological, innovative activity and the best Russian practices.

At the present stage as indicated by statistical indicators the regions' role in the development of science and technology in the country seems insufficient. Thus, the share of budget funds of the Russian Federation' subjects and local budgets in the aggregate amount of domestic expenditure on R&D in 2016 was 1.7% (compared to the previous year, the indicator grew by 0.3%), and the federal budget funds – 53.7%. The funds of regional and local budgets are mainly finance the public sector structures - 3.7%, higher education sectors - 2.9%, and business sector - only 0.5%.

The subject of this study is the regional environment that promotes the development of scientific activity, and the study's purpose is to reveal the level of regional environment's intensity in general and for individual indicators that identify it in the Russian Federation's subjects.

At present, there is no clear definition of the concept under investigation in the literature, while the environmental concept has gained wide popularity and is used as a base for studying the problems and processes of the regional economy.

The essence of the concept is that the research object is not simply a collection of participants, economic entities, conditions and norms for their functioning in a certain territory, but a special reality that creates effective promises to the development of certain activities in the region, taking into account the interrelations and synergies between subjects and structures that determine not only direct, but also indirect impact on participants within its borders.

In the literature to a greater extent is researching an innovative regional environment that was originally identified by researchers as a regional innovation system (Braczyk et al., 1998). Later, its interpretation evolved and began to be based on the network principle. Thus, Kamagni defined it as "a set of network complex informal social relations in a limited geographical space, often defining the external image and extra specifically internal representations and feelings of "belonging" that stimulate the territory's innovation through synergistic and collective learning processes" (Camagni, 1991). In the works of Kostianen (Kostianen, 2002) the innovative environment is treated as a system of innovative networks and institutions located within a certain geographical area, which, with regular and strong internal interaction, increase the region's innovation.

Domestic researchers characterize the innovation environment as the environment of the participant in the innovation process, which has an indirect or direct impact on the conditions of innovation activity and its result (Golova, 2008; Golova et al., 2017); as the environment formed as a result of the interrelation and interaction of innovation activity's subjects under the regulatory effect of legal and regulatory and economic mechanisms regarding the creation, circulation and use of innovations (Kotov, 2012).

Summarizing the given points of view and translating them into the problems of scientific activity's development in the regions, for the purposes of this study the regional environment that promotes the development of scientific activity is defined as the aggregate of subjects (in case of its high development it is the system),

their relationships and legal, financial, administrative and other conditions that has a direct and indirect influence on scientific activity sphere within the territory of the Russian Federation's subject and with the regular and strong impact it increasing its effectiveness. The urgency of researching the issues of the current state of development of scientific activity in the regions is due to the special importance of the R&D sector for outstripping growth in the economies of the Russian Federation's subjects, which is indicated in the Strategy for Scientific and Technological Development of the Russian Federation.

Materials And Methods

The general approach to construction of Index of the regional scientific environment's is based on a conceptual scheme for assessing the created conditions and the available potential of the Russian Federation' subjects for solving the tasks of the Strategy for Scientific and Technological Development. Within the framework of this approach, the indicators of the scientific and technological development of the regions are considered systematically, in the analytical perspective, which allows to give a comprehensive assessment of the studied processes and the factors affecting them.

Index of the regional scientific environment of the Russian Federation's subject is based on indicators characterizing the five key factors of scientific and technological development:

- conditions for involving young people in science and popularizing the researcher's career (F1);
- a set of material, technical and financial conditions for the development of scientific activity (F2);
- conditions for communication and collaboration between researchers, commercialization of research and development (F3);
- an effective system of management and coordination of scientific activities in the region (F4);
- conditions for the integration of Russian science into the international space (F5).

Index of the regional scientific environment (IRSE) consists of two index-components: the Index of potential (IP) and Index of result (IR).

In addition, the indicators in each thematic block (factor) are also conditionally combined into 2 subindex - the subindex of the potential and the subindex of the result (Figure 1).

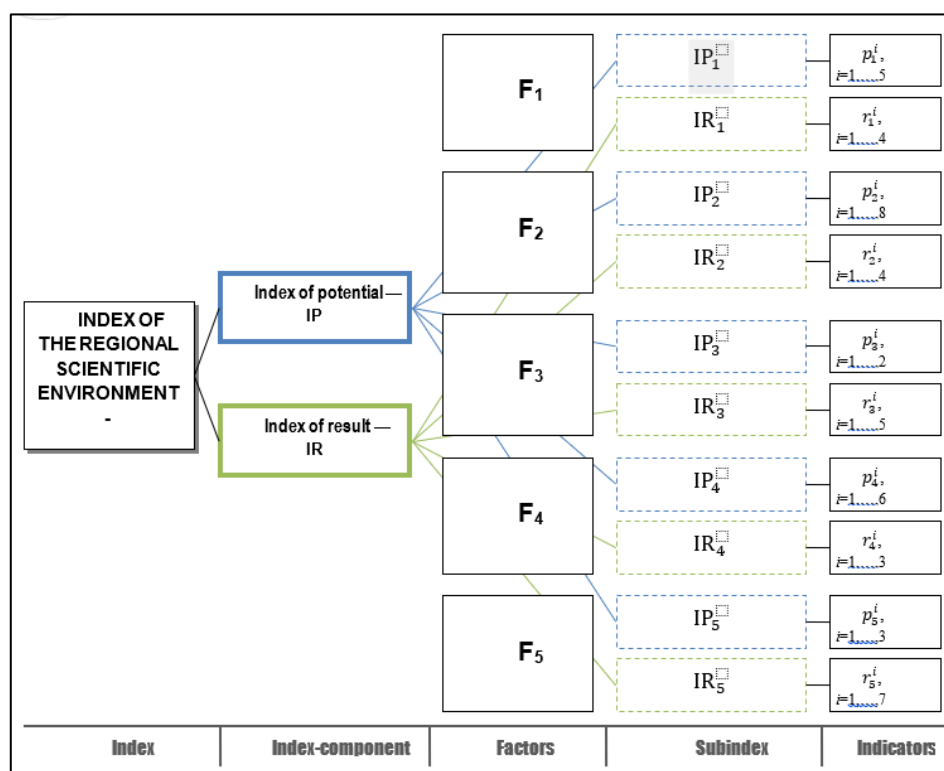

Figure 1 - Structure of Index of the Regional Scientific Environment of the Russian Federation's subject

Thus, the IRSE is built on the basis of aggregation of indicators' values, notably aggregation is occurring at several levels, allowing to rank the regions' ratings according to certain factors and directions of scientific and technological development (potential or result).

The IRSE calculation model is based on the aggregation of 47 primary indicators. The indicators were taken in relative terms for comparability and for taking into account the scales of the scientific environment of different regions (Table 1).

Table 1 - Indicators used for calculation the Index of the regional scientific environment

FACTOR OF SCIENTIFIC AND TECHNOLOGICAL DEVELOPMENT	INDICATOR NAME	METHOD OF CALCULATION
	INDICATORS OF POTENTIAL	
Conditions for involving young people in science and popularizing the researcher's career	Number of established children's technology parks "Quantorium"	Number of children's technology parks established in the region within the framework of the Priority Project "Accessible Supplementary Education for Children"
	Number of Centers for Youth Innovation Creativity (CYIC)	Number of Centers for Youth Innovation Creativity established in the region
	Number of premiums in the field of regional science	
	Number of personal scholarships' types for researchers at the regional level	The number of types of awards, scholarships, grants, competitions, enshrined by the current normative-legal act of the regional level
	Number of grants types and competitions for young scientists of regional level	
The aggregate of material, technical and financial conditions for the development of scientific activity	Number of created engineering centers engaged in R&D per 1000 organizations	The number of open tenders' winners of the Ministry of Education and Science of the Russian Federation for the provision of state support for projects for the creation and development of engineering centers, referred to the number of region's organizations engaged in R&D, divided by 1000
	Number of created common use centers engaged in R&D per 1000 organizations	The number of common use centers registered in the official database of the Ministry of Education and Science of Russian Federation, referred to the number of region's organizations engaged in R&D, divided by 1000
	Number of unique scientific installations per 10000 researchers	The number of unique scientific installations registered in the official database of the Ministry of Education and Science of Russian Federation, referred to the number of researchers divided by 10000
	Availability of a competition of fundamental research projects conducted by the Russian Foundation for Basic Research jointly with the Russian Federation's subjects	Availability (absence) of the joint competition of Russian Foundation for Basic Research and region
	Number of regional funds supporting scientific activities	Number of funds that provide financial support for scientific research, popularization of science and created by the executive authorities of the region
	The volume of budgetary funds in the region, that provided basic and	The total amount of funds provided for the conducting of fundamental and

	applied scientific research, per 1 researcher, thousand rubles.	(or) applied scientific research, provided for in the expenditure part of the laws on the budgets of the Russian Federation's subjects, referred to the number of researchers in the region
	Share of the regional budget funds that provided the support of program activities for the development of scientific activities and conducting of fundamental and applied scientific research	The share of expenditures for conducting fundamental and (or) applied scientific research, activities that include the development and support of scientific activities, state programs of the Russian Federation's subjects in the total amount of budget expenditures in accordance with the laws on Russian Federation's subjects budgets
	Share of budgetary funds of the Russian Federation's subject and local budgets in financing of internal costs for R&D	The volume of budgetary funds of the Russian Federation's subject and local budgets allocated for the financing of R&D, to the value of internal costs for R&D
Conditions for communication and collaboration between researchers, commercialization of R&D	The number of created clusters per 1000 organizations engaged in R&D	The number of clusters registered in the official database of the Ministry of Education and Science of Russian Federation, referred to the number of organizations in the region engaged in R&D, divided by 1000
	Number of created technology parks per 10000 researchers	The number of technology parks registered in the official database of the Ministry of Education and Science of Russian Federation, that is referred to the number of researchers divided by 10000
Effective system of management and coordination of scientific activities in the region	Availability in the structure of region's executive bodies of the unit supervising scientific activities	Availability (absence) in the structure of region's executive bodies of the ministry (department, administration, office), supervising scientific activity (in accordance with the structure's official name)
	Availability of a coordinating structure (council) for scientific activity	Availability (absence) of a structure (council) officially established by the region's executive authorities, which coordinates scientific activity (in accordance with the official name of the structure (council))
	Availability of the current normative legal act on scientific activity	Availability (absence) of a normative legal act regulating scientific activity in the Russian Federation's subject (in accordance with the name and content)
	The number of state programs in the region, including the main measures to support scientific activity	The number of state programs of the Russian Federation's subject, where there are subprograms and (or) measures aimed at the development of scientific activities and its support (in accordance with the names of programs, subprograms, activities)
	Availability of a vector of scientific and technological development in tasks and objectives of the region's strategy for social and economic development	Availability (absence) of the vector of scientific and technological development in tasks and objectives of the region's strategy for social and economic development (in accordance with the content)

	Participation in development and approbation of the regional model of the National Technological Initiative	The presence of the subject among the winners of the regional competition of National Technological Initiative
	Number of foreign scientists who worked in scientific organizations and universities in the region on 100 organizations engaged in R&D	Number of foreign scientists involved in the implementation of R&D, and worked in the reporting year in a university (organization), referred to the number of organizations in the region engaged in R&D, divided by 100.
Conditions for the integration of Russian science into the international space	Number of regional universities, participants of "5-100" project	Foreign scientists from leading scientific and educational centers (organizations) is counted The number of universities participating of "5-100" project located in the region
	Number of researchers assigned to work in leading Russian and international scientific, scientific and educational organizations per 100 researchers	Number of researchers assigned to work (internship) in the reporting year in leading Russian and international scientific, scientific and educational centers (organizations) lasting not less than a calendar week for the period 2011-2016, referred to the number of researchers divided by 100
INDICATORS OF RESULT		
	The average score of the Uniform state exam on budget places in the region's universities	The average scores of the Uniform state exam, taking into account the number of students enrolled in budget places at the competition, for all universities in the region, given in the Monitoring of the quality of admission to higher education institutions, conducted by the Higher School of Economics
Conditions for involving young people in science and popularizing the researcher's career	Number of winners and prize-winners of the All-Russian Olympiad for schoolchildren / number of graduates in the region	The average annual number of winners and prize-winners of the All-Russian Olympiad for schoolchildren for the period under study, referred to the number of region's graduates
	Number of recipients of grants and scholarships of the President of the Russian Federation to support young scientists per 100 researchers with academic degrees	The total number of recipients of grants and scholarships of the President of the Russian Federation to support of young scientists during the contest period, referred to the number of researchers with academic degrees divided by 100
	Number of post-graduate students and doctoral students per 10000 people	The cumulative number of post-graduate students and doctoral students at the end of the reporting period, referred to the region's population divided by 10000 people
The aggregate of material, technical and financial conditions for the development of scientific activity	Number of winners of the Russian Science Foundation competitions per 100 organizations engaged in R&D	The cumulative number of all competitions winners of the Russian Science Foundation for the entire period of the fund's activity, referred to the number of organizations engaged in R&D, divided by 100
	Number of winners of the Federal Targeted Program "Research and Development in Priority Areas for the Development of the Russian Science and Technology Complex for 2014-	The cumulative number of all competitions winners of the Federal Targeted Program "Research and Development" for the whole period of the program's operation, referred to

	2020" per 100 organizations engaged in R&D	the number of organizations engaged in R&D, divided by 100
	Internal costs for R&D on average per 1000 organizations, thousand rubles.	The costs for R&D carried out by the own forces of regional organizations, including current and capital costs, during the reporting year, regardless of the source of financing, referred to the number of enterprises and organizations of the region divided by 1000
	Number of created (developed) advanced production technologies per 100 organizations engaged in R&D	Number of developed technologies and technological processes (including equipment that necessary for their implementation), computer-controlled or microelectronic based and used in the design, production or processing of products (goods and services), referred to the number of organizations engaged in R&D divided by 100
	Organizations' innovative activity	The ratio of the number of organizations that carried out technological, organizational or marketing innovations to the total number of organizations surveyed for a certain period of time in the region
	The number of created small innovative enterprises (SIE) per 100 organizations engaged in R&D	The number of small innovative enterprises recorded in the official database of the Ministry of Education and Science of Russia, referred to the number of organizations engaged in R&D, divided by 100
Conditions for communication and collaboration between researchers, commercialization of R&D	Number of winners of the megagrants program per 1000 organizations engaged in R&D	The cumulative number of winners of megagrants competitions conducted in accordance with the Resolution of the Government of the Russian Federation No. 220, referred to the number of organizations engaged in R&D, divided by 1000
	Number of winners of the competition for the development of cooperation of Russian universities, scientific institutions and manufacturing enterprises per 1000 organizations engaged in R&D	The total number of winners of competitions for the development of cooperation of Russian universities, scientific institutions and manufacturing enterprises conducted in accordance with the Resolution of the Government of the Russian Federation No. 218, referred to the number of organizations engaged in R&D, divided by 1000
	Indicator of the number of potentially commercialized patents per 1000 researchers	The indicator is the sum of the number of received Russian patents with a coefficient of 0.08 and PCT-patents with a coefficient of 0.5 (Zemtsov et al., 2016), referred to the number of researchers divided by 1000
Effective system of management and coordination of scientific activities in the region	Number of staff engaged in R&D per 10000 people	Workers on payroll of organizations (relevant units: educational organizations of higher education, industrial organizations, etc.) that carried out R&D, as of the end of the reporting year, referred to the

	<p>Average salary in the R&D sector, thousand rubles</p> <p>The number of highly-productive jobs created in the R&D sector, in the total number of highly-productive jobs in the region</p> <p>The number of created results of intellectual activity that has legal protection outside the Russian Federation in average per 1 researcher</p> <p>The cumulative number of publications in the Scopus database per 100 people engaged in R&D</p> <p>The cumulative number of publications in the Web of Science database per 100 people engaged in R&D</p> <p>The cumulative citedness of publications in the Scopus database in average per 1 organization engaged in R&D</p> <p>The cumulative citedness of publications in the Web of Science database in average per 1 organization engaged in R&D</p> <p>Number of articles prepared jointly with foreign organizations in average per 1 organization engaged in R&D</p> <p>Number of agreements on the export of technologies and services of a technical nature per 100 organizations engaged in R&D</p>	<p>region's population divided by 10000 people</p> <p>Average monthly nominal accrued wages of R&D organizations' employees, thousand rubles</p> <p>The number of highly-productive jobs by type of economic activity "R&D", referred to the total number of highly-productive jobs in the region</p> <p>Number of foreign patents received by region's organizations in the reporting year, referred to the number of researchers</p> <p>The cumulative number of publications in the Scopus database, referred to the number of staff engaged in R&D, divided by 100 people</p> <p>The cumulative number of publications in the Web of Science database referred to the number of staff engaged in R&D, divided by 100 people</p> <p>The cumulative citedness of scientific publications published over the past five years (including the reporting year) in journals indexed in the Scopus database, referred to the number of organizations engaged in R&D</p> <p>The cumulative citedness of scientific publications published over the past five years (including the reporting year) in journals indexed in the Web of Science database, referred to the number of organizations engaged in R&D</p> <p>The number of scientific publications that simultaneously has affiliations of organizations and foreign organizations (Web of Science, Scopus), referred to the number of organizations engaged in R&D</p> <p>The number of all commercial transactions on the export of technologies and services of a technical nature, including transactions of branches, representative offices of foreign organizations operating in the Russian Federation, referred to the number of organizations engaged in R&D, divided by 100</p>
<p>Conditions for the integration of Russian science into the international space</p>		

All used indicators are normalized (they are transferring into an estimate in the range from 0 to 1) in order to calculate the IRSE. Data is normalized before aggregation is performed to ensure that the same unit of measurement is used in the data set.

For the study purposes, the minimax normalization is used by the following formula:

$$\bar{x}_{ij} = \frac{(x_{ij} - x_{min,j})}{(x_{max,j} - x_{min,i})} \quad (1)$$

where $i = 1, \dots, N$, N — number of objects, in our case it is 85 subjects of the Russian Federation; $j = 1, \dots, m$, m — number of indicators x_{ij} ($m=47$).

Thus, we obtained the **normalized indicators**:

indicator of potential — $\bar{p}_{k,j}^i$

indicator of result — $\bar{r}_{k,j}^i$,

where k — the number of the thematic block (factor), $k = 1, \dots, 5$; $i = 1, \dots, n$, n — number of indicators included in the relevant subindex, $j = 1, \dots, N$, N — number of Russian Federation's subjects, $N=85$.

Values of subindexes of potential IP_k^j for each thematic block (factor) are calculated by the distance method according to the formula:

$$IP_k^j = \sqrt{\frac{\sum_{i=1}^n (1 - \bar{p}_{k,j}^i)^2}{n}} \quad (2)$$

where k — the number of the thematic block (factor) ($k = 1, \dots, 5$), n — number of indicators included in the relevant subindex of potential, $j = 1, \dots, N$, N — number of Russian Federation's subjects, $N=85$.

Similarly, the values of the subindexes of the result IR_k^j are calculated by the formula:

$$IR_k^j = \sqrt{\frac{\sum_{i=1}^n (1 - \bar{r}_{k,j}^i)^2}{n}} \quad (3)$$

The evaluation of the indexes-components - the Index of potential IP^j and the Index of result IR^j — for each region j are calculated as the product of estimates subindex of potential and of result of each factor respectively.

$$IP^j = \prod_{k=1}^5 IP_k^j \quad (4)$$

$$IR^j = \prod_{k=1}^5 IR_k^j \quad (5)$$

The general **Index of the regional scientific environment** of the Russian Federation's subject $IRSE^j$ is defined as the product of indexes-component:

$$IRSE^j = IP^j \times IR^j \quad (6)$$

where $j = 1, \dots, N$, N — number of Russian Federation's subjects, $N=85$.

In addition, we calculated **Index of factor** IF_k^j in each thematic block (factor) for all regions:

$$IF_k^j = IP_k^j \times IR_k^j \quad (7)$$

where k — number of the corresponding factor ($k = 1, \dots, 5$), $j = 1, \dots, N$, N — number of Russian Federation's subjects, $N=85$.

Results

The rating of the regional scientific environment, which is the result of ranking the regions in descending order of $IRSE$ values, is displayed in Table 2.

Table 2 - Top-10 of rating of the Russian Federation's subjects by the value of the Index of the regional scientific environment

Region	IRSE rank	IRSE	IPrank	IP	IR rank	IR	IF ₁ rank	IF ₂ rank	IF ₃ rank	IF ₄ rank	IF ₄ rank
Moscow	1	1,000	1	1,000	1	0,989	1	1	32	1	5
St. Petersburg	2	0,997	5	0,869	2	0,975	3	5	20	2	3
Tomsk Region	3	0,996	2	0,909	3	0,959	5	2	7	3	1
Novosibirsk region	4	0,991	4	0,879	4	0,927	7	6	26	4	2
Republic of Tatarstan	5	0,983	3	0,889	7	0,844	4	9	4	8	6
Nizhny Novgorod Region	6	0,971	31	0,634	5	0,922	10	3	22	6	28
Belgorod region	7	0,970	6	0,814	8	0,836	8	4	2	37	4
Moscow region	8	0,965	13	0,701	6	0,883	25	8	47	5	10
Kaluga region	9	0,947	9	0,743	10	0,792	47	13	34	7	23
Sverdlovsk region	10	0,931	19	0,693	12	0,775	38	19	49	9	13

The top-10 of regions with the highest Index of the regional scientific environment are: Moscow, St. Petersburg, Tomsk Region, Novosibirsk Region, Republic of Tatarstan, Nizhny Novgorod Region, Belgorod Region, Moscow Region, Kaluga Region, Sverdlovsk Region.

Leading positions of Moscow (the value of IRSE - 1) and St. Petersburg (0.997) is explained by the fact that these two metropolitan regions are political, economic, financial and scientific centers of the Russian Federation. However, the indicators of the scientific and technological development of Moscow and St. Petersburg can not be attributed to unrepresentative in relation to other regions, since the IRSE values for all leading regions are quite high - from 0.931 (Sverdlovsk Region) to 0.996 (Tomsk Region).

Tomsk region situated on the third line is today one of the leading scientific and educational centers in Russia. The program of innovative development is implemented on its territory one of the first. The largest universities of the Tomsk region are included in a galaxy of the best higher educational institutions of Russia. In addition, the region is rich in natural resources.

Novosibirsk region, which occupies the fourth position, is the largest scientific center not only of the Siberian Federal District, but of all Russia. A significant part of the scientific and educational complex of Siberia is concentrated in this region, the core of which is the Siberian Branch of the Russian Academy of Sciences. One of the strongest innovative infrastructure in Russia has been created and is actively developing in the Novosibirsk region.

The Republic of Tatarstan, Belgorod region, Nizhny Novgorod region, Kaluga region,

Moscow region and Sverdlovsk region are industrial and innovatively developed regions, centers of attraction of human resources and investment flows, demonstrating a high concentration of economic and business activity. Here, both scientific research centers and high-tech industrial enterprises are concentrated. In addition, the Republic of Tatarstan, Nizhny Novgorod, and Kaluga regions were included in the group of leaders of Ranking of Russian Federation Regions for the significance of the Russian regional innovation index in 2016 prepared by the Institute of Statistical Studies and National Research University Higher School of Economics.

The level of differentiation of the Russian Federation's subjects according to the IRSE, calculated as the ratio of the IRSE values for the region that leading in rating and the subject that is last in it, is 2.9 times. It should be noted that it is much smaller than the ranges of variation of the values of indexes-component of the result and potential - 18.8 and 4.9 times, respectively. This suggests that the backlog in certain indicators and factors of scientific and technological development in some regions is compensated by a significant advantage in others indicators and factors.

Since the final index is in some way a smoothed out estimate, to some extent balancing the different components of regions' scientific environment, it is important to supplement the IRSE data on the indexes-component and the individual factors of the development of the regional scientific environment.

The analysis of the particular ratings of the Russian Federation's subjects in terms of Index of potential, Index of Result and selected factors

that form the general IRSE rating showed the stability of the results of such regions as Moscow, St. Petersburg, Tomsk Region, Novosibirsk Region, Republic of Tatarstan, Belgorod region and Kaluga region. All of them are included in the top-10 of rating for both indexes.

However, among the regions included in the top-10, only in the Tomsk region (3rd place) and in the Republic of Tatarstan (5th place) all five development factors of the scientific environment are evenly developed. In Moscow, St. Petersburg and the Novosibirsk region, there is a lag in the third factor "Conditions for communication and collaboration between researchers, commercialization of R&D," 32nd, 20th and 26th places, respectively; in the Belgorod region - on the fourth factor - "Effective system of management and coordination of scientific activities in the region" (37th place); in the Kaluga region - at once on two factors - the first (47th place) and the third (34th place).

Some indicators were insufficiently high for the Moscow region: the first factor of scientific and technological development "Conditions for involving young people in science and popularizing the researcher's career" - 25th place in the rating and the third factor "Conditions for communications and collaborations between researchers, commercialization of R&D" - 47th

place in the rating. It did not allow the region to enter the top 10 by the Index of result.

A similar situation is for the Nizhny Novgorod region. There is sagging in the third factor - 22nd place and in the fifth factor "Conditions for the integration of Russian science into the international space" - 28th place.

Sverdlovsk region is not among the top-10 of ratings for indexes-component, but its rankings has a high enough value and a small spread of 19 and 12, which allowed it to enter the top-10 leaders of the IRSE rating.

As for the outsider regions, in general there is a sustained lag in both the indexes-component and certain factors of development of the scientific environment. In the Chukotka Autonomous District there is a significant lag in the 1st, 2nd and 5th factors of scientific and technological development. In Jewish Autonomous Region the 2nd, 3rd and 4th factors are substantially less developed, in the Nenets Autonomous District - the 1st, 3rd and 4th factors are substantially less developed.

The final results of the IRSE rating are visualized using the intensity map of the regional scientific environment development of the Russian Federation's subjects (Figure 2).

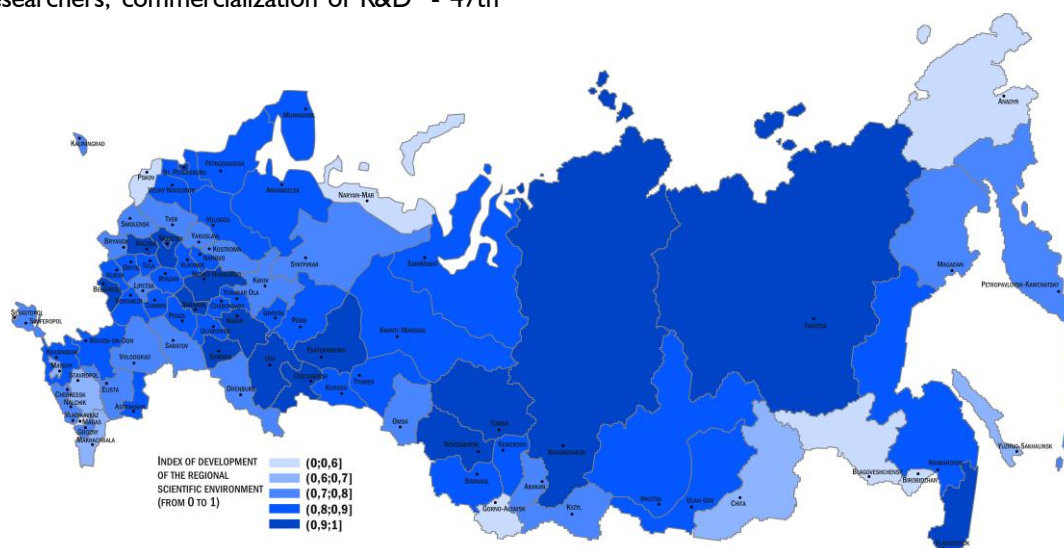

Figure 2 - Intensity map of the regional scientific environment development

Discussion

In this article we tried to trace the positions of the regions-leaders in the ranking of the regional scientific environment developed by the authors, in various Russian rankings - indexes formed by such research organizations as HSE (Rating of innovative development of Russian Federation's subjects, 2017), RIA Rating (Level of development of science and technology in the Russia's regions. Rating, 2017). and Association of Innovative Regions of Russia (Rating of Innovative Regions of Russia), conducting regional comparisons on

various economic, financial and infrastructural data in the field of science and innovation. These indexes not only demonstrate the advantages and disadvantages of certain subjects of the Russian Federation and the processes taking place in them from different perspectives, they are quite a powerful information resource for creating certain ideas about a particular region and its development potential for the coming years.

Analysis of the regions' positions in the listed ratings showed that both the group of leading regions in the development index of the regional scientific environment and the group of outsiders largely coincide with the leaders of the above ratings in 2016 (Table 3). This further confirms that the level of development of the regional scientific environment influences the innovative, scientific and technological development of the region.

Table 3 - Comparative analysis of the positions of the regions-leaders of the rating of the regional scientific environment in other ratings

Region	Rating of the regional scientific environment	Rating of innovative development of Russian Federation's subjects	Rating of scientific and technological development of Russian Federation's subjects	Rating of Russia's innovative regions
	developed by the authors	National Research University Higher School of Economics	RIA-rating	Association of Innovative Regions of Russia
Moscow	1	2	1	1
St. Petersburg	2	3	2	2
Tomsk region	3	9	10	4
Novosibirsk region	4	11	13	5
Republic of Tatarstan	5	1	3	3
Nizhny Novgorod region	6	4	4	8
Belgorod region	7	18	32	29
Moscow region	8	14	6	9
Kaluga region	9	6	24	6
Sverdlovsk region	10	17	8	13

Analysis of the region's positions in these rankings for 2016 shows us that 5 of the 10 leading regions in IRSE rating (Moscow, St. Petersburg, Tomsk region, the Republic of Tatarstan, Nizhny Novgorod region) are in the top 10 of all ratings mentioned above. Novosibirsk region positionally close to the rank in the ranking IRSE in other ratings, it should be noted that, being located on the 11th place in the Rating of innovative development of the Russian Federation, the region is included in the Group I of the Russian regional innovation index.

Moscow and Kaluga regions, which occupy the 8th and 9th positions in the author's rating, are in the Top 10 in 2 out of 3 considered ratings.

Positional similarities in outsiders in author's rating with other ratings selected for comparison, are less significant than for the leaders, but, nevertheless, regions-outsiders of IRSE rating are not occupy high positions in other ratings (except 26th place of Sakhalin region in the HSE rating).

The analysis of the data presented in the table confirms the hypothesis put forth by the authors that regions with a high rating of the regional scientific environment has high ranks in the innovation sphere.

It seems viable to use the experience of successful regions both in the development of the regional scientific environment and in the innovation sphere.

Conclusion

It is possible to give the following recommendations for the development of the regional scientific environment based on the Index of Development of Regional scientific

Environment obtained in the study, the structure of which corresponds to the five key tasks of the Strategy for Scientific and Technological Development of the Russian Federation:

Improvement of the regulatory and legal framework for the organization of scientific, scientific and technological activities, the formation of scientific, scientific and technological policies in the regions;

Overcoming the fragmentation of the coordination mechanisms for scientific, scientific and technological activities and the formation of specialized structures in the regions that supervise scientific, scientific and technological activities in order to effectively use the intellectual, scientific and technological potential of the territories in the interests of economy's development;

Creation of new and expanding activities of existing coordination, advisory and consulting bodies on science and scientific and technological policy under the authorities of the Russian Federation's subjects in order to increase the importance of the R&D sector in the regional economy and to take full account of the views of the academic community during making strategic decisions;

Creation of conditions for involving young people in science through the implementation of new models of additional education and involving children and young people in participating in events organized by specialized regional structures, stimulating scientific and innovative activities within the framework of a developed system of competitions, grants, prizes;

Increasing the regions' participation in creating if conditions for improving the material and technical components of the regional scientific environment: creating new and developing existing structures (centers of common use, engineering centers, technology parks, etc.), unique equipment that facilitate technological breakthroughs.

Expanding the practice of attracting resources from regional sources for R&D implementation: increasing the financing of basic and applied research from the budget of the Russian Federation's subjects; an increase of items in regional budgets that support program measures for the development of scientific activities and conducting of fundamental and applied scientific research; funding of scientific research from regional funds supporting science, scientific, scientific and technological activities, expanding the practice of cooperation with federal funds and similar structures;

Increasing the participation of regional authorities in the development of collaborations and communications between structures generating R&D in the region and their potential customers, as well as expanding the practice of forming integrated scientific and technological projects with involving all stakeholders;

Increasing the competitiveness and academic reputation of the country's leading universities (cardinal expansion of their international integration both in the field of educational programs, and in the field of R&D).

Expanding of international cooperation at the regional level using effective practices of supporting and developing of various forms of international cooperation in the field of science, technology, innovation by actively attracting foreign scientists to the Russian scientific space and integrating Russian researchers into the world's scientific networks of mobility.

Acknowledgements

The article is the result of the research funded by the Ministry of Education and Science of the Russian Federation within the research project «Change and Development Management of Scientific Organizations in the Context of the State Policy of their Restructuring» implemented by Tver State University.

References

- Berezina EV, Lebedev KV, Pluzhnova NA, Prokhorova LV, Fedin AV. (2017). Statistics of science and education. Issue 5. Organizations And Personnel Engaged In Research And Development. [Internet]. Available from: http://csrs.ru/archive/stat_2017_institutions/institutions_2017.pdf
- Braczyk H-J, Cooke P, Heidenreich M. (1998). *Regional Innovation Systems*. London: Routledge.
- Camagni R. (1991). Introduction: from the local «milieu» to innovation through cooperation networks. *Innovation Networks: spatial perspectives*. London: Bedhaven Press, p.1–9.
- Golova IM. (2008). Innovative climate of the region as a condition of social and economic

development. Author's abstract of dissertation of doctor of Economic Sciences. Ekaterinburg.

Kostiainen J. (2002). Urban Economic Development Policy in the Network Society. Finland: Tekniikan akateemisten liitto, Tampere.

Kotov DV. (2012). Methodology of formation and development of innovation environment in the region. Author's abstract of dissertation of doctor of Economic Sciences. Ufa.

Level of development of science and technology in the Russia's regions. Rating. (2017). [Internet]. Available from: <http://riarating.ru/infografika/20171017/630075019.html>

Rating of innovative development of Russian Federation's subjects. (2017). [Internet].

Available from: <https://www.hse.ru/primarydata/rir>

Rating of Innovative Regions of Russia. [Internet]. Available from: <http://i-regions.org/reiting/rejting-innovatsionnogo-razvitiya>

Strategy of scientific and technological development of the Russian Federation. [Internet]. Available from: <http://www.consultant.ru/law/hotdocs/48053.html/>

Zemtsov S, Muradov A, Wade I, Barinova V. (2016). Determinants of Regional Innovation in Russia: Are People or Capital More Important? *Foresight and STI Governance*, 10(2): 29–42.